

ROUND TABLE - Ø280 MM & 380 MM

DESIGNED BY PJ PRODUCTION & HANS THYGE & CO

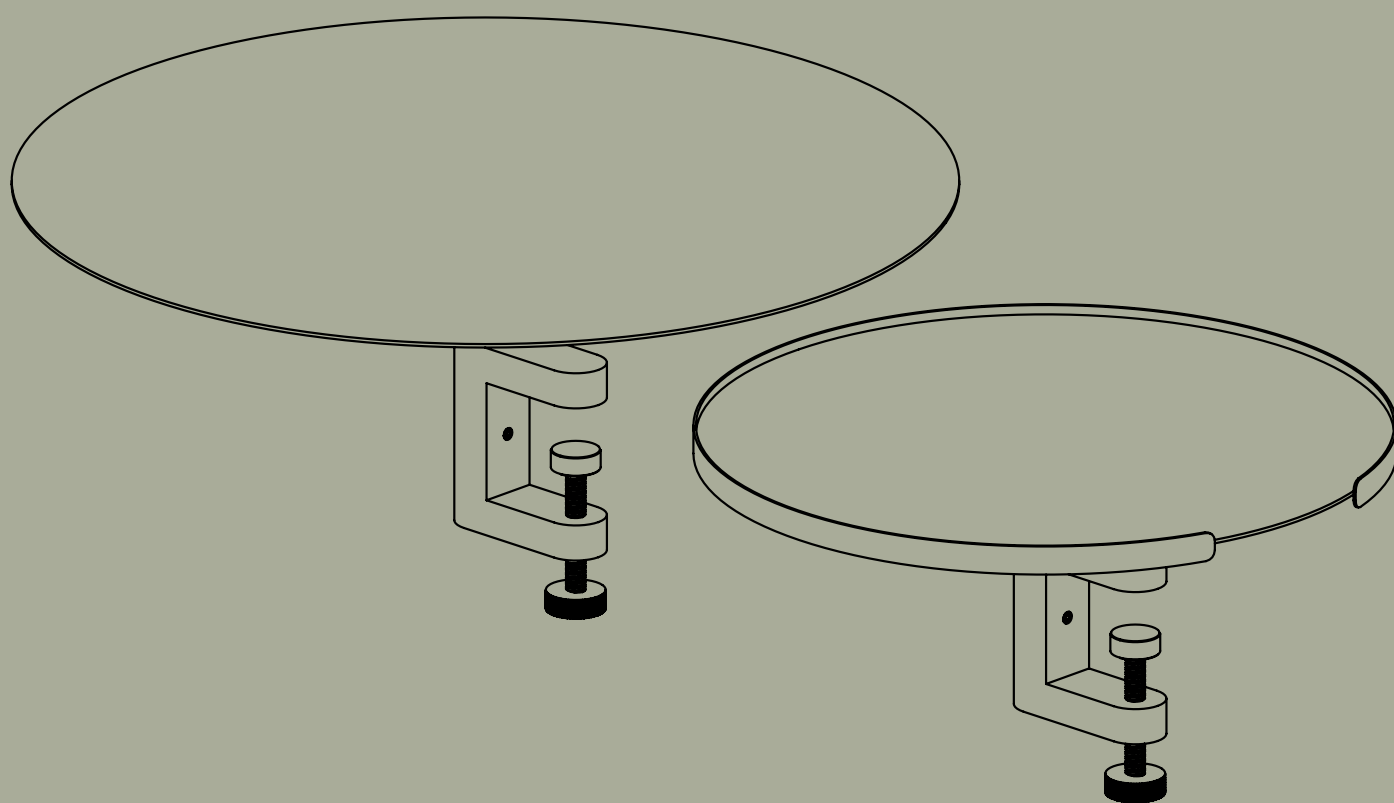

APTO

PARTS

This instruction manual is equal for following: round table - Ø280 mm and round table - Ø380 mm. The different parts for the particular item numbers are illuminated below. Note: the instruction manual is made with the large version measuring Ø380 mm.

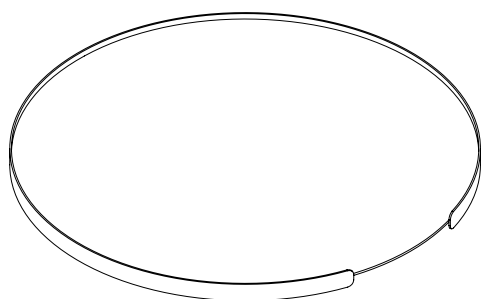

1 x Ø280 mm table top

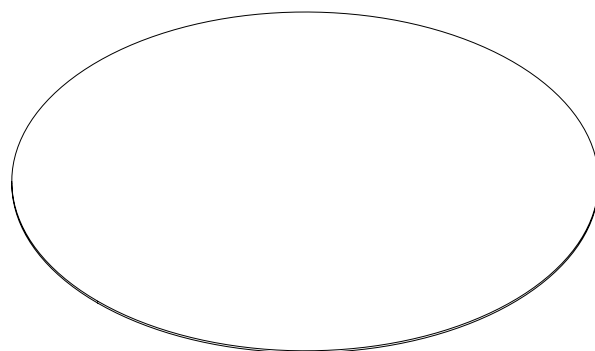

1 x Ø380 mm table top



1 x tube



1 x tube



1 x socket screw



1 x socket screw

ROUND TABLE - Ø280 MM

Nordic Dark Blue: 6000-0014-5008
Danish Dusty Green: 6000-0014-7033
Scandinavian Matte Black: 6000-0014-9000

ROUND TABLE - Ø380 MM

Nordic Dark Blue: 6000-0018-5008
Danish Dusty Green: 6000-0018-7033
Scandinavian Matte Black: 6000-0018-9000

APTO

WHAT YOU WILL NEED

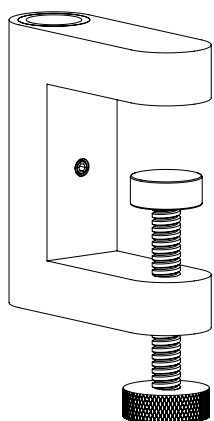

1 x MULTI CLAMP

Nordic Dark Blue: 6000-0000-5008
Danish Dusty Green: 6000-0000-7033
Scandinavian Matte Black: 6000-0000-9000

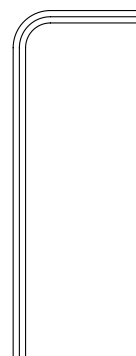

1 x ALLEN WRENCH

The Allen wrench is included in the multi clamp box

STEP 1

Carefully connect the table top and the tube manually by hands in a clockwise fashion until the tube has been sufficiently tightened.

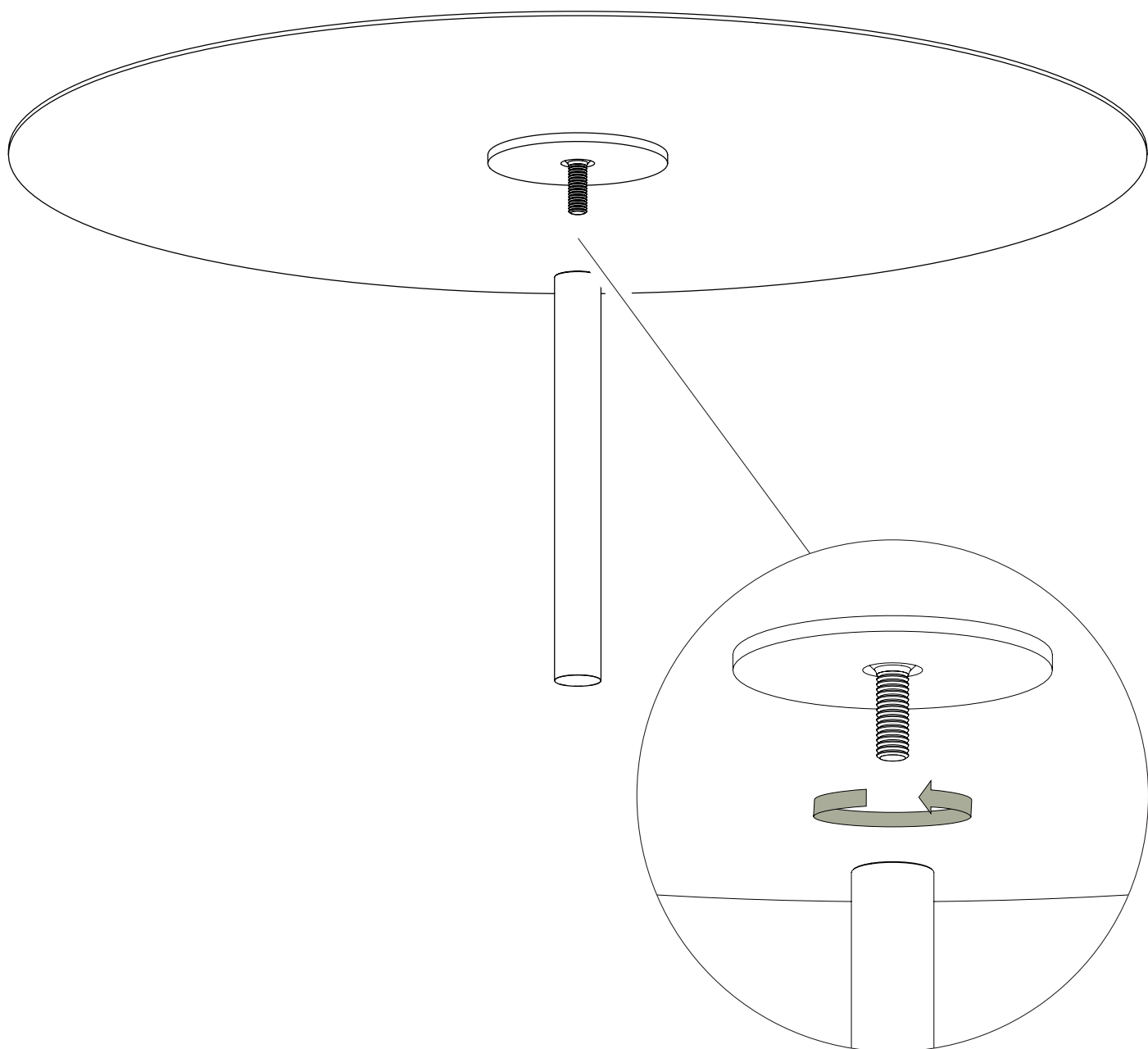

APTO

STEP 2

Carefully lead the socket screw through the hole in order to fastened and stabilize the round table.

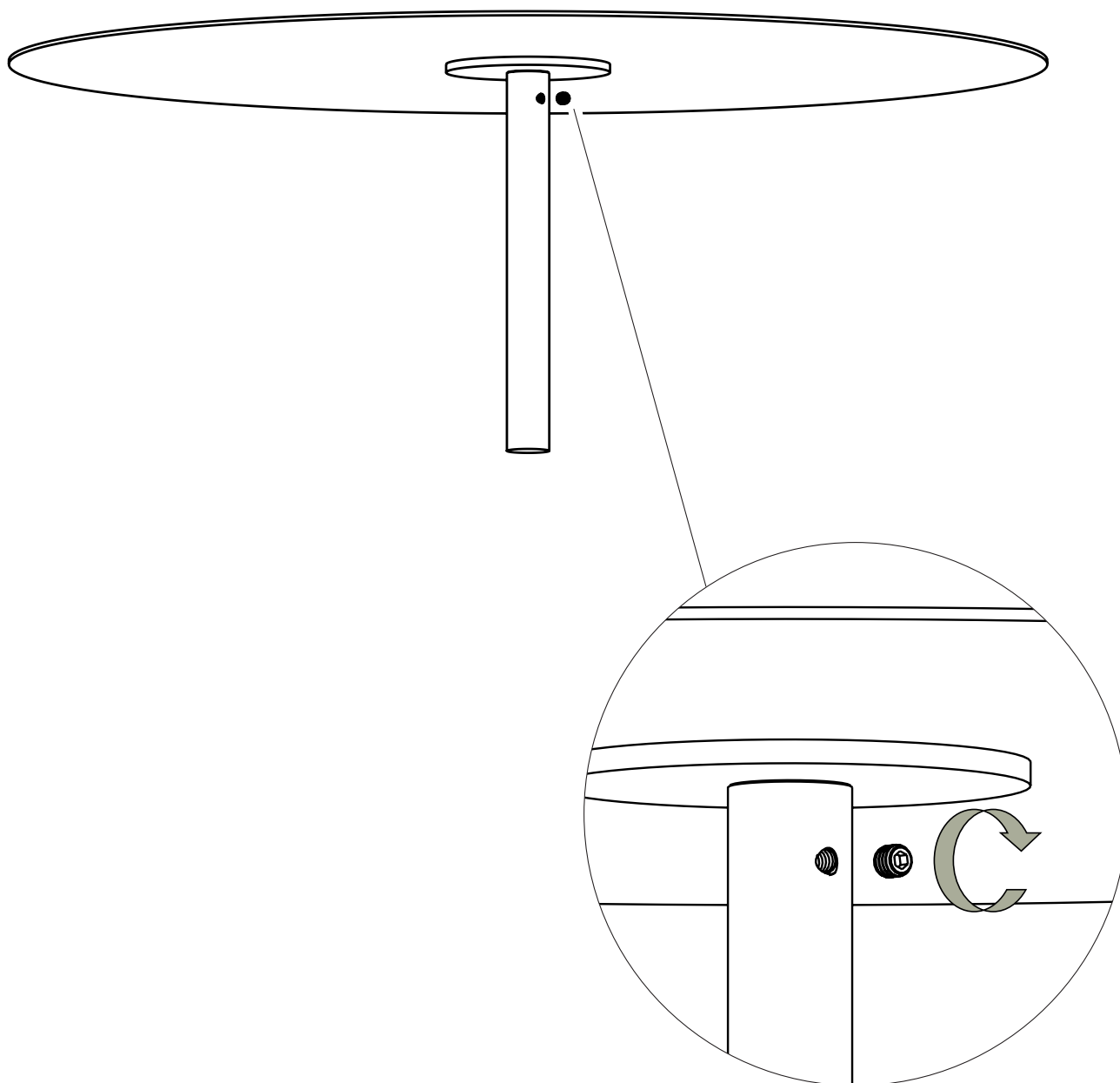

APTO

STEP 3

Carefully lead the tube through the hole at the top of the multi clamp

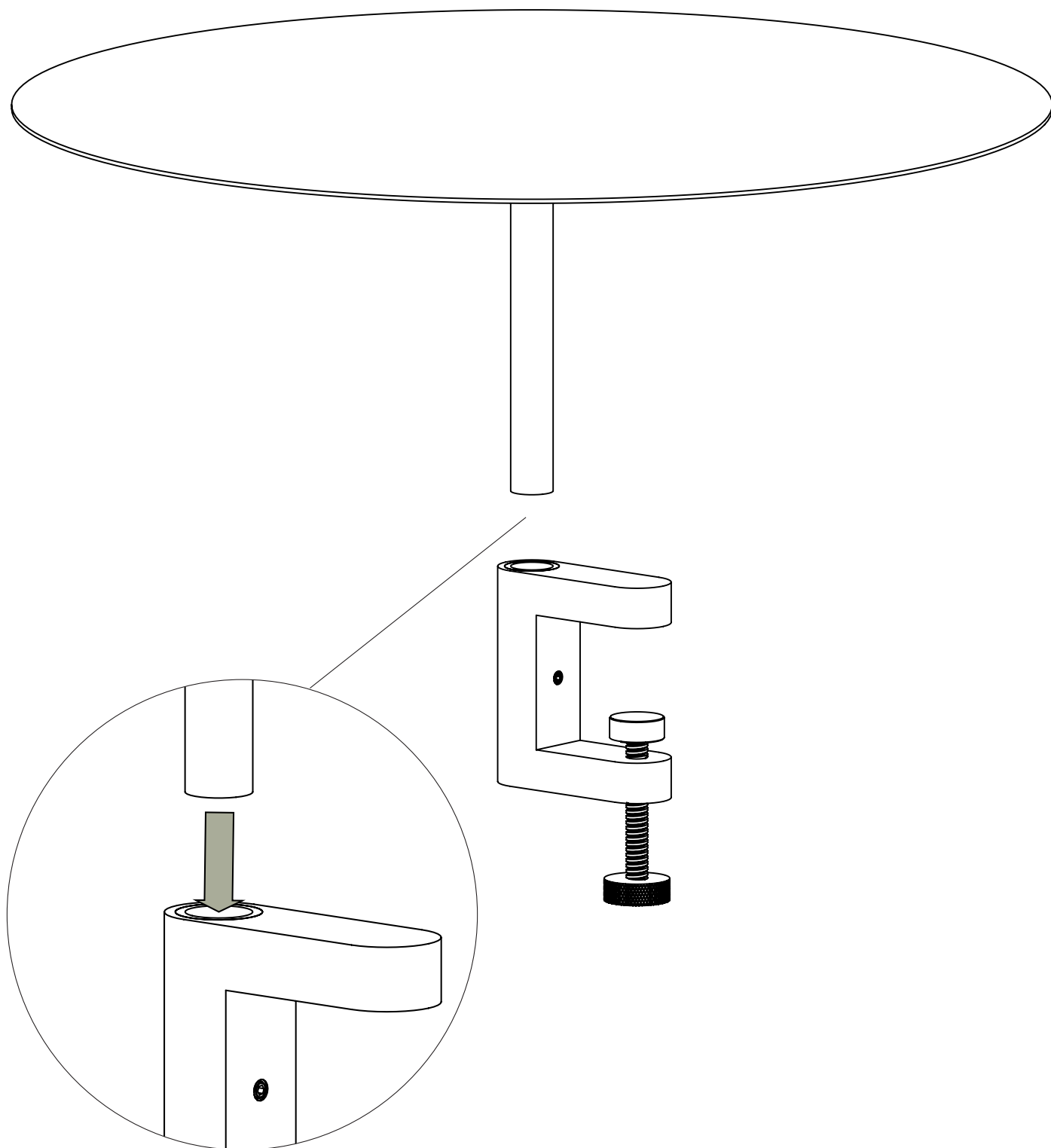

APTO

STEP 4

The finger screw must be open entirely before continuing. Now carefully insert the tip of the Allen wrench into the hexagon cross section of the socket screw and turn the wrench in a clockwise fashion until the socket screw has been sufficiently tightened.

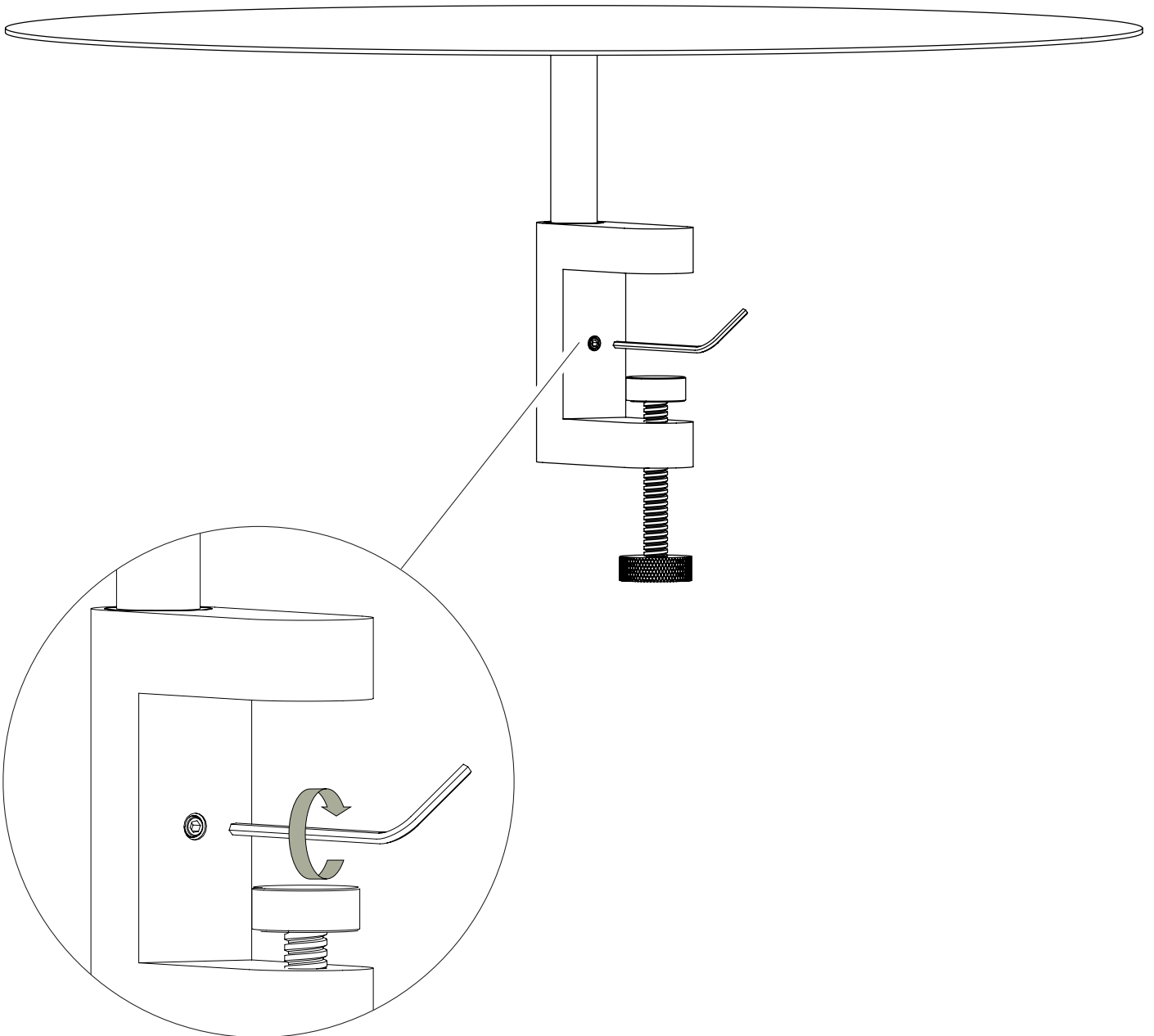

APTO

STEP 5

The round table can now be attached to the preferred surface.

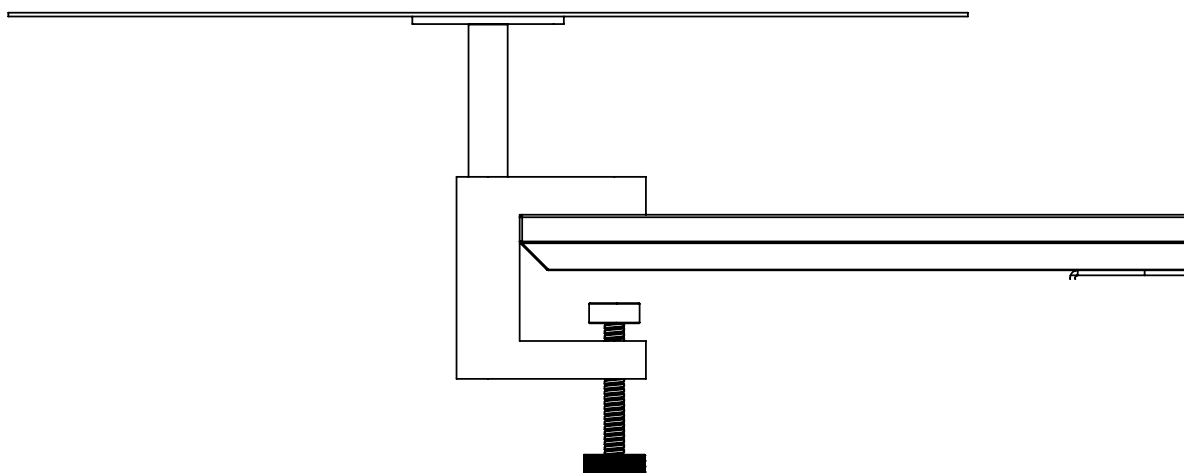

APTO

STEP 6

When the placement of the round table is correctly, then tighten the finger screw completely.

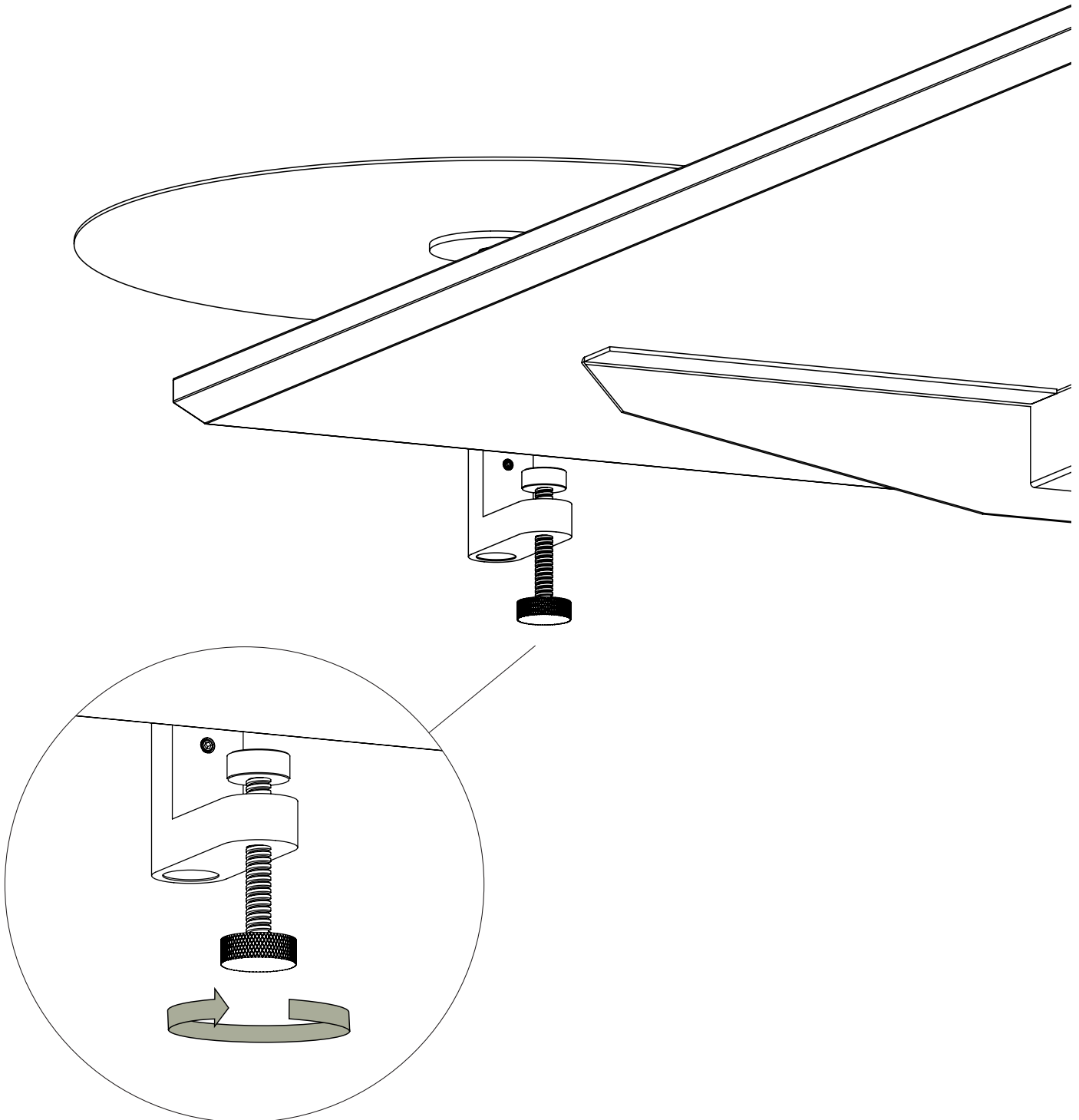

APTO

Hårup Skovej 2, 8600 Silkeborg, Danmark
+ 45 86 81 23 75 // www.aptocollection.dk

APTO
DANISH DESIGN